

## Development of NC Power Based on Buck Circuit

Yuxing Ouyang, Fengzhi Dai\*, Runhua Mao, Ce Bian, Baochang Wei, Yiqiao Qin, Shengbiao Chang, Qijia Kang

*College of Electronic Information and Automation, Tianjin University of Science and Technology,  
1038 Daguananlu Road, Hexi District, Tianjin, 300222, China*

*E-mail: \* dai fz@tust.edu.cn*

*www.tust.edu.cn*

### Abstract

This paper develops a kind of power-supply module which uses digital control and buck circuit. The module can convert 220v alternating current into 0-30V direct current. In the aspect of circuit design, it is mainly AC-DC, DC-DC conversion circuit and SCM minimum system circuit. In the aspect of control circuit, for feedback signal of current sensor, the power-supply module can obtain average value by multiple means and remove the mutation value.

*Keywords:* Buck circuit, SCM, AC-DC conversion circuit, DC-DC conversion circuit

### 1. Introduction

With the development of power electronic technology and digital control technology, more and more devices combine these two technologies. This paper develops a power module which combines MCU with Buck circuit to enhance the digital control of the power supply module to a certain extent to make up for the lack of traditional power supply module<sup>1</sup>.

At present, the traditional power conversion circuit uses TL494 as the PWM signal generator and the MOS tube as the switch element. The voltage regulation is realized by building analog circuits and adjusting the resistance of sliding rheostat or potentiometer to change the duty ratio of PWM.

A closed-loop system can also be formed by building an analog circuit, but this closed-loop system has a simple structure and low anti-interference ability. The most important thing is that this conversion method which based on analog circuits has its own insurmountable shortcomings, such as the inability to display parameters such as voltage and current in real time and the disadvantage of not being able to adjust in real time. Moreover, the conventional power conversion

circuit has a complicated structure, low stability, easy to generate errors, and consumes a certain amount of energy because it needs to withstand a large amount of resistance.

The main circuit of the NC power based on Buck circuit is divided into the following three modules: The first module is AC-DC conversion circuit. Its function is to convert the 220V AC to the 30V DC through a transformer, a bridge rectifier module and filter capacitor; the second module is the DC-DC conversion circuit. Its function is to convert the 30V DC to the 0-30V DC through the Buck circuit; the third module is the microcontroller control circuit, its main function is to protect the special requirements of constant voltage or constant current, through reading the current sensor feedback signal and adjust the PWM duty cycle to change the voltage output<sup>2</sup>.

This paper is organized as follows. Section 2 describes the hardware circuit design, and Section 3 introduces the control strategies. The main circuit simulation is implemented in Section 4, and the conclusions are presented in Section 5.

## 2. The hardware circuit design

The basic circuit of the system is divided into step-down rectifier filter circuit, Buck circuit, measurement circuit, SCM supply circuit, 430F149 minimum system circuit, LCD liquid crystal display circuit and independent key circuit. The step-down rectifier filter circuit is discussed in Section 2-1. Section 2-2 describes the Buck circuit. Section 2-3 introduces the 430F149 minimum system circuit<sup>3</sup>.

### 2-1. The step-down rectifier filter circuit

This circuit includes the transformer, full-bridge rectifier and filter capacitor. The role of the transformer is to convert 220V AC to 30V AC. After the rectification action of the full bridge rectifier module, the alternating current is converted to direct current, but the waveform of the direct current is unstable. Using the filter capacitor can make the DC waveform more stable<sup>4</sup>. The step-down rectifier filter circuit is shown in Fig.1.

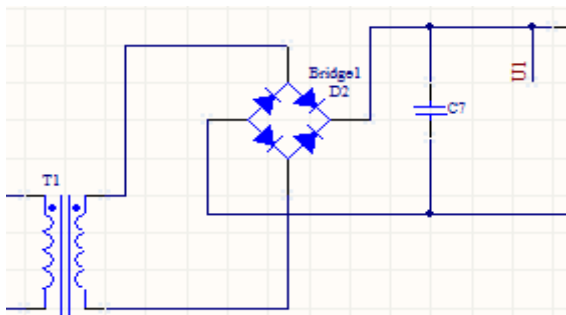

Fig.1 The step-down rectifier filter circuit

### 2-2. The Buck circuit

Buck circuit is mainly composed of the MOS tube IRF540, inductor, capacitor and freewheeling diode. MOS tube IRF540 mainly used in the circuit as a high-power switching components, is the core of the DC-DC circuit. The diode protects the entire circuit by preventing the reverse flow of current. Inductance and capacitance form a low-pass filter, making the circuit output current waveform smoother. The buck circuit is shown in Fig.2.

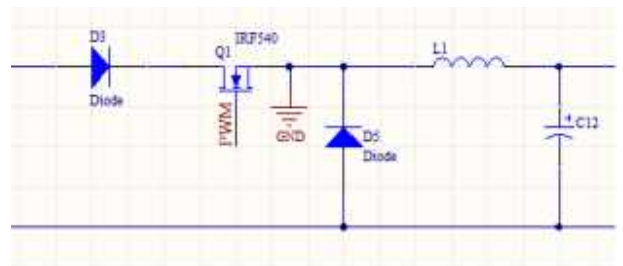

Fig.2 The buck circuit

### 2-3. The circuit of the system

Other circuits are related to the control chip. 430F149 microcontroller peripheral circuits include reset circuit, crystal oscillator circuit and power supply circuit. Power supply circuit mainly uses the LM7805 regulator module and LM117 regulator module. This part of the circuit can be about 30V DC voltage into 3.3V DC voltage, so as to provide a stable microcontroller voltage. The circuit of the system is shown in Fig.3.

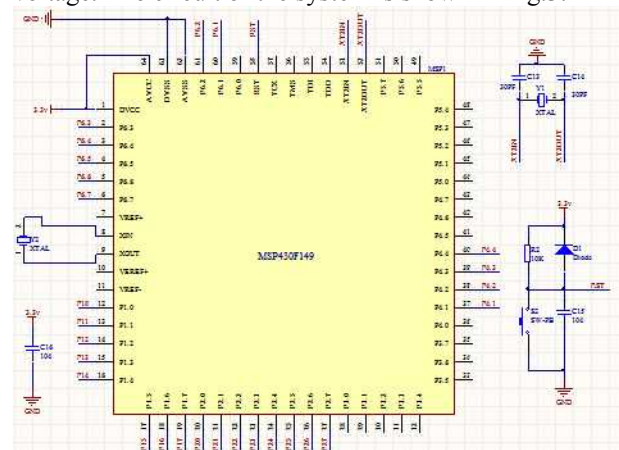

Fig.3. The circuit of the system

## 3. The control strategies

Good hardware circuits and powerful control ICs play a crucial role in NC power, but control strategies are also an integral part of maintaining the proper operation of a device<sup>5</sup>. For the NC power developed in this paper, the control strategy is mainly used in the chips on the ACS712 current sensor module feedback signal processing. The system can be based on the signal to adjust the PWM signal output. However, due to the sensor itself may be some problems, we can improve the situation to some extent through data processing. The PWM signal output must also have a certain control

strategy, in order to improve the voltage conversion capability of the entire system<sup>6</sup>.

Because the ACS712 current sensor feedback is an analog signal, when subjected to external interference may be abrupt changes in value, making the measurement error. The control strategy adopts the method of filtering the mutation value and obtaining the average value. We remove each group of five data with larger absolute deviation value and retain the five data with smaller absolute deviation value. A total of 25 sets of data for the five groups, we again average these 25 data, the average as the true value of the feedback signal.

After obtaining the feedback value of the data processing, we use the difference between the feedback value and the set value to adjust the duty cycle of the PWM. Because the load will have a certain voltage and current limit, so we adjust the PWM duty cycle, the step value should not be too large, to prevent overshoot. However, if the step value is too small will affect the adjustment time, making the adjustment time increases, which will not be conducive to real-time response of the entire system. Therefore, we set the threshold method to adjust the PWM duty cycle. When the difference between the actual feedback value and the set value is larger, we adopt a larger step value to adjust the duty cycle of the PWM, and when the actual feedback value approaches the set value, reduce the step value.

Through this strategy, the voltage conversion ability of the entire system can be well improved, and the real-time response of the whole system is good.

#### 4. The main circuit simulation

The maximum input voltage of LM78XX series voltage regulation module is 36V, so the voltage after the filter module of variable voltage rectifier must be reduced below 36V. Buck circuit which capacitance and inductance parameters will directly affect the time that system circuit to reach steady-state. So, we need to go through a software simulation to find one or more sets of optimization data. Section 4-1 introduce the AC-DC conversion simulation circuit. Section 4-2 introduce the buck circuit simulation.

#### 4-1 The AC-DC conversion simulation circuit

In the AC-DC conversion simulation circuit, we set three measurement points, namely the input voltage  $U_i$ , transformer output voltage  $U_{i1}$  and rectified output voltage  $U_1$ . We use voltmeters and oscilloscopes as measurement tools. The oscilloscope detects the waveform of the final output voltage  $U_2$  and the time it takes for the voltage to reach steady-state time. The simulation result of AC-DC circuit is shown in Tab.1.

Tab.1 The simulation result of AC-DC circuit

$U_i$ (V)	n1:n2	$U_{i1}$ (V)	$U_1$ (V)	C( $\mu$ F)	T(ms)	W
220	7:1	31.149	42.357	500	4.924	S
220	8:1	27.492	36.768	500	4.924	S
220	9:1	24.437	32.688	500	4.924	S
220	10:1	21.993	29.234	500	4.924	S

(Note: C: Filter capacitor, T: steady-state time, W: Waveform, S: stable.)

If we hope that the final output voltage of the overall circuit  $U_2$  range between 0-30V, then its AC-DC circuit part of the output voltage values  $U_1$  which after rectification must be above 30V. Taking into account the MOS tube IRF540 protection and as much as possible to reduce the heating power, AC-DC circuit output voltage values should be as close to 30V. According to the above two points, when we select the transformer turns ratio is 9: 1 turns the circuit can make the output voltage value  $U_1$  is 32.688V.

#### 4-2 The buck circuit simulation

Buck circuit as the core circuit of the NC power supply studied in this paper will directly affect the efficiency of the entire system, so the parameters of each component is particularly important<sup>7</sup>. We through the circuit simulation to determine the Buck circuit capacitance, inductance parameters. Select the optimal parameters to keep the output waveform stable, reducing the time it takes for the Buck circuit to reach steady state.

From the experimental data in Tab.2 we can know that actual simulation values and theoretical values are different. Experimental data show that when we select the capacitance and inductance of the larger values, the longer the time required to reach steady state, but the waveform is relatively smooth. When the selected capacitance and inductance is small, although the

steady-state time is shorter, but the waveform is unstable. So, we choose the capacitance and inductance parameters should choose the middle value, so we choose 470uF and 100mH.

Tab.2 The simulation result of Buck circuit

U1(V)	D	TV(V)	SV(V)	L <sub>1</sub> (mH)	C <sub>2</sub> (uF)	S(ms)
32.688	20%	6.538	5.915	100	470	203.4
32.688	40%	13.075	12.590	100	470	247.6
32.688	60%	19.613	19.388	100	470	255.2
32.688	80%	26.240	25.981	100	470	272.1
32.688	90%	29.412	29.285	100	470	250.5
32.688	90%	29.412	29.149	1000	470	397.4
32.688	90%	29.412	29.275	10	470	101.7
32.688	90%	29.412	29.275	100	47	68.7
32.688	90%	29.412	29.338	100	4700	799.9

(Note: D: Duty cycle, TV: Output theoretical value, SV: Output simulation value, S: Steady-state time)

From the circuit simulation results we can see that we can determine the transformer turns ratio of 9: 1, and in the Buck circuit, the specific value of the capacitor is 470uF and the inductor value is 100mH.

### 5. Conclusion

Developed in this paper based on Buck circuit NC power supply, which can output any value between 0-30V stable voltage, but also real-time display current and voltage values and other parameters. The device can not only be used as a constant current source to a certain extent, but also can freely switch between a constant current source and a constant voltage source.

We are free to set the working hours of the equipment programmatically and enable the equipment to automatically calculate and display the voltage, current and consumed energy values across the load and enable the automatic alarm function when these values reach the limit. At the same time, we incorporated data

processing and control strategies to ensure the stability of the equipment and formed a closed-loop control system. In the whole system, the analog circuit part is responsible for the voltage conversion, the digital control part is responsible for the regulation of the system, and the two parts work independently and complement each other, so that the power supply module is intelligentized and the device can be more safely and steadily for the load Power supply<sup>8</sup>.

### Acknowledgements

The research is partly supported by the Research Fund for the Reform in Education from Tianjin Municipal Education Commission of China (171005704B).

### References

1. Chun-Wei Feng, Wei-Feng Min, Juan Lei. Design of a High-precision Numerical Control LED Constant Current Driver. *Electronics World*, 14(14): 113-114, 2017.
2. Yin-qiao Li, Yu-Ling Liu, Xue-Feng Liu, Shan Huang. Design of NC DC power supply based on MSP430. *Computer Measurement and Control*, 24(12): 231-233+236, 2016.
3. Zhen-Feng Xiao, Rong-Xiang Yuan, Xiang-Tian Deng, Xiao-Lei Liu. Remote Intelligent Fault Monitor Based on MSP430F169. *Electric Power Automation Equipment*, 33(01): 160-164, 2013.
4. Zheng-Sen Jiang. Homemade Raiders of Precision CNC Power Supply. *Journal of Radio*, (9): 58-63, 2012.
5. Xiu-Hua Wang. NC Constant Current Source Based on Integrated Switching Regulator Chip. *Power Technology*, 5: 738-739, 2012.
6. Tian-Chen Huang, Song Jia, Jian-Hua Yu. Design and Realization of High Precision NC DC Current Source. *Instrumentation Technology and Sensor*, (6): 27-29, 2013.
7. Zhong-Hua Yun, Huan-huan Yin, Yong-Feng Li. Simulation and Research of DC Buck Chopper in Multisim. *Application Engineering of Computer Engineering*, (16): 216-218, 2015.
8. Zhao-Lin Huang, Wen-Tong Wu, Xiao-Jun Jing, et al. Design of precision numerical control direct current power supply. *Control Automation*, 8(8): 134-137, 2011.